

Axia GPIO Breakout to RJ45

Part # A15-B01-2 (Rev 2 Board)

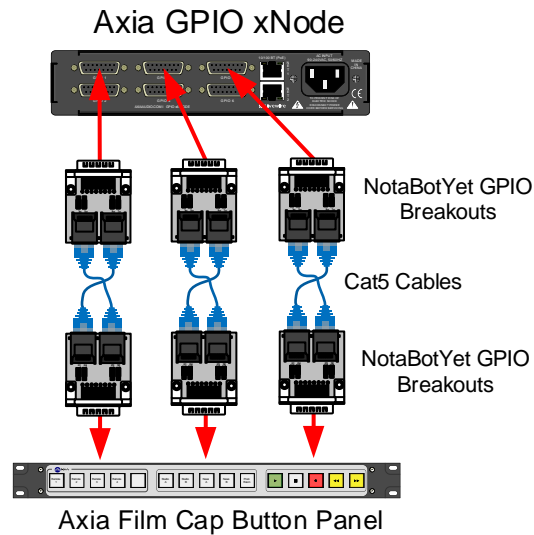
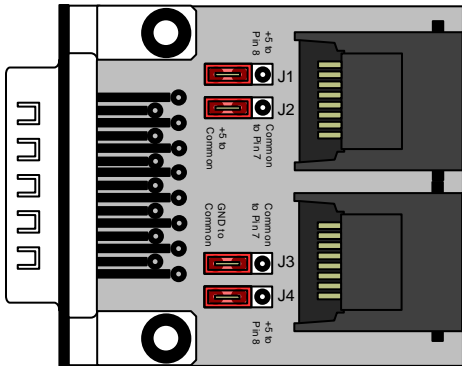

Installation Example

Purpose: The *Axia GPIO Breakout* was designed to provide an easy breakout for the five open collector inputs and outputs of a standard Axia GPIO port. Use of category 5/6 wiring and RJ-45 type connectors is a much faster and efficient way of connecting equipment within a broadcast plant and this device eliminates the need for soldering to a 15 pin D-SUB type connector. In addition, in modern wiring plants, category 5/6 cables are usually already in place or can be easily put in place meaning this device can allow utilization of existing wiring infrastructure for the transport of GPIO signals.

Inputs: Inputs are available on a convenient RJ-45 connector allowing the use of standard category 5/6 wiring to transport GPIO control within your plant.

Outputs: Outputs are available on a convenient RJ-45 connector allowing the use of standard category 5/6 wiring to transport GPIO control within your plant.

Jumpers: Jumpers on this board allow for common configurations and simplification of standard wiring but also allow all pins to be available directly on the RJ45 connector if needed.

Jumper J1 will allow the user to connect +5V directly to Pin 8 on the RJ-45 "IN" connector. The default is disabled to protect the +5v supply in the Axia node from inadvertent shorting.

Jumper J2 will connect +5V from the Axia directly to the Axia common input (default) or will patch the common input directly to Pin 7. This allows the inputs to only need be shorted to ground to activate.

Jumper J3 will connect +GND from the Axia directly to the Axia common output (default) or will patch the common output directly to Pin 7. This means that when an output is active, it is pulled to ground level.

Jumper J4 will allow the user to connect +5V directly to Pin 8 on the RJ-45 "OUT" connector, which may be required by some NotaBotYet accessories, or if connecting to an Axia Film Cap Button Panel. The default is disabled to protect the +5v supply in the Axia node from inadvertent shorting.

RJ45 Input Pinout:

Pin Number	EIA/TIA 568B Wire Color
1	GND Org/W
2	In 1 Org
3	In 2 Grn/W
4	In 3 Blu
5	In 4 Blu/W
6	In 5 Grn
7	In Com Brn/W (Jumper Dependent)
8	+5V Brn (Jumper Dependent)

RJ45 Output Pinout:

Pin Number	EIA/TIA 568B Wire Color
1	GND Org/W
2	Out 1 Org
3	Out 2 Grn/W
4	Out 3 Blu
5	Out 4 Blu/W
6	Out 5 Grn
7	Out Com Brn/W (Jumper Dependent)
8	+5V Brn (Jumper Dependent)